

UNS2K40CA

ROHS

Surface Mount Transient Voltage Suppressor

Description

The UNS is designed for DC power supply equipment in outdoor exposure environment. It is used to replace the traditional PTC, GDT and TVS combination solution, which is widely used to DC24V、DC12V port.etc
Working Voltage: 40V

Features

- ◆ Glass passivated junction
- ◆ Excellent clamping capability
- ◆ Repetitive rate (duty cycle):0.01%
- ◆ Low profile package and low inductance
- ◆ 2000A Peak Pulse power capability at 8/20us waveform
- ◆ Fast response time: typically less than 1.0ps from 0V to VBR min
- ◆ High temperature soldering:260°C/40s at terminals
- ◆ For surface mounted application in order to optimize board space
- ◆ Plastic package has Underwriters Laboratory Flammability 94V-0
- ◆ Halogen free and RoHS compliant
- ◆ IEC-61000-4-2 ESD 30kV(Air), 30kV (Contact)
- ◆ ESD protection of data lines in accordance with IEC 61000-4-2
- ◆ EFT protection of data lines in accordance with IEC 61000-4-4

Applications

TVS devices are ideal for the protection of I/O interfaces, Vcc bus and other vulnerable circuits used in Telecom, Computer, Industrial and Consumer electronic applications.

Maximum Ratings and Thermal Characteristics (TA=25°C unless otherwise noted)

Parameter	Symbol	Value	Unit
Peak pulse current with at 1.2/50μs-8/20μs@2Ω waveform	I _{PP}	2000	A
Steady state power dissipation at T _L =75°C	P _D	6.5	W
Junction and storage temperature range	T _J , T _{STG}	- 55 to +150	°C
Operating temperature range	T _{OP}	- 55 to +125	°C



www.unsemi.com.tw

Bi-directional

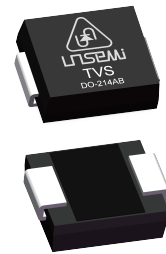

Functional Diagram

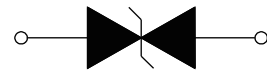

Electrical Characteristics (@ 25°C Unless Otherwise Specified)

Part Number	Marking	Reverse Stand-Off Voltage V_{RWM} (V)	Breakdown Voltage V_{BR} (V) @ I_T		Test Current I_T (mA)	Maximum Clamping Voltage V_c @ I_{PP} (V)	Maximum Peak Pulse Current I_{PP} (A)	Maximum Reverse Leakage IR @ V_{RWM} (μ A)
			MIN	MAX				
UNS2K40CA	2K40CA	40	44.40	49.10	1	75	2000	1

NOTE1: Surge waveform: 1.2/50 μ s-8/20 μ s@2 Ω waveform

V_R : Stand-off Voltage -- Maximum voltage that can be applied

V_{BR} : Breakdown Voltage

V_c : Clamping Voltage -- Peak voltage measured across the suppressor at a specified I_{PP}

IR: Reverse Leakage Current

Ratings and Characteristic Curves ($T_A=25^\circ\text{C}$ unless otherwise noted)

Figure 1 - Pulse Waveform

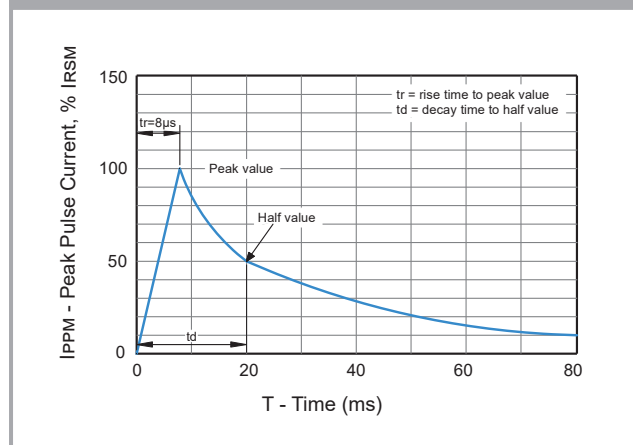

Figure 2 - Pulse Derating Curve

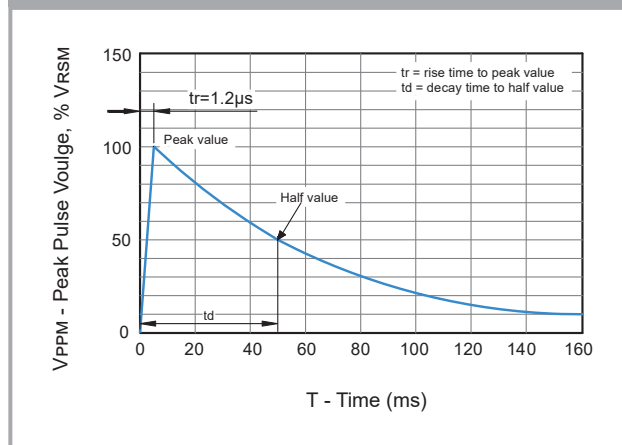
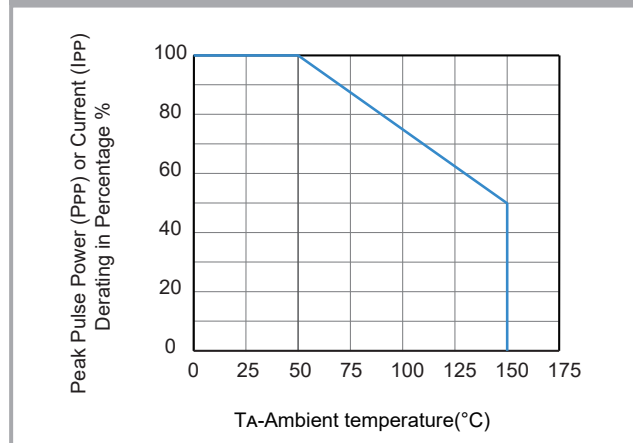
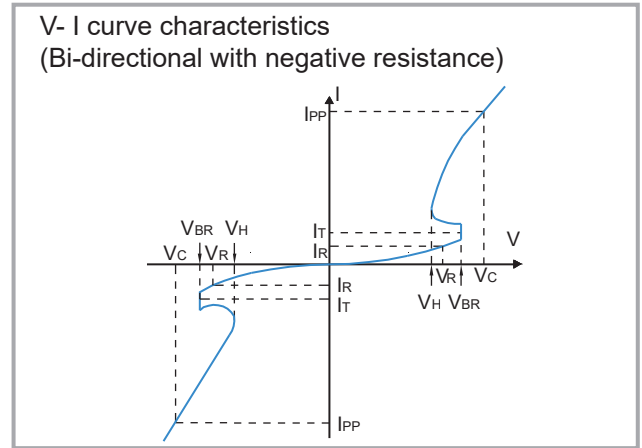
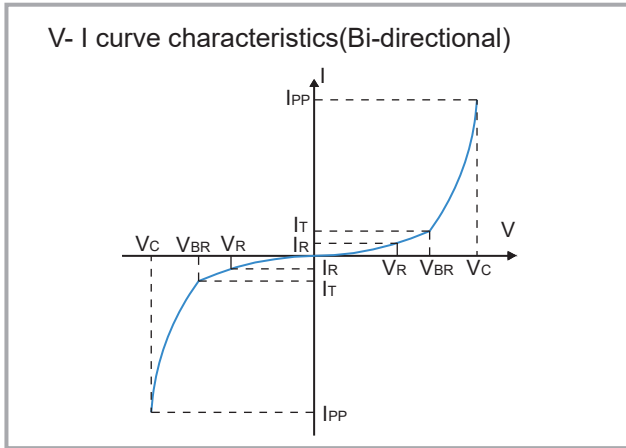

Figure 3 - Pulse Derating Curve



I-V Curve Characteristics



Part Numbering

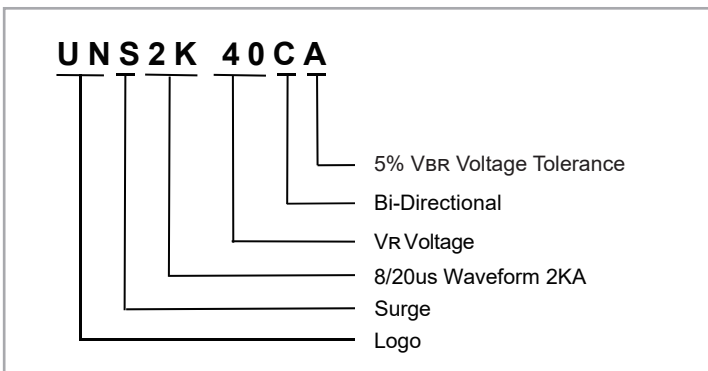

Soldering Parameters

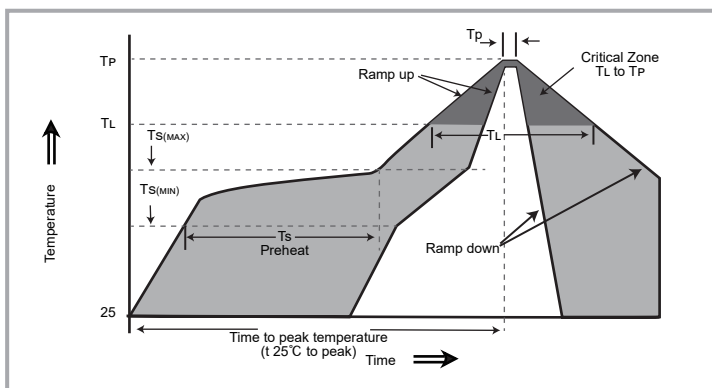

Reflow Condition		Lead-free assembly
Pre Heat	- Temperature Min (Ts(min))	150°C
	- Temperature Max (Ts(max))	200°C
	- Time (min to max) (Ts)	60 -180 Seconds
Average ramp up rate (Liquidus Temp TL) to peak		3°C/second max
Ts(max) to TL - Ramp-up Rate		5°C/second max
Reflow	- Temperature (TL) (Liquidus)	217°C
	- Time (min to max) (Ts)	60 -150 Seconds
Peak Temperature (TP)		260 +0/-5°C
Time within 5°C of actual peak Temperature (TP)		20-40 Seconds
Ramp-down Rate		6°C/second max
Time 25°C to peak Temperature (TP)		8 minutes Max
Do not exceed		260°C

Dimensions

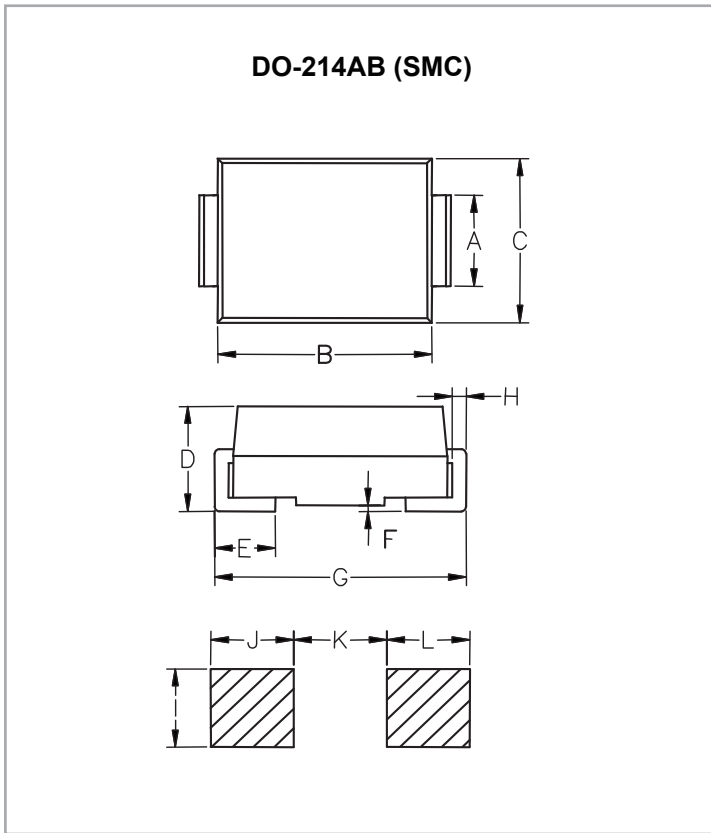

Dimensions	Inches		Millimeters	
	Min	Max	Min	Max
A	0.114	0.126	2.86	3.160
B	0.260	0.280	6.520	7.020
C	0.220	0.245	5.520	6.150
D	0.079	0.103	1.980	2.590
E	0.030	0.060	0.750	1.510
F	-	0.008	-	0.203
G	0.305	0.320	7.640	8.020
H	0.006	0.012	0.152	0.305
I	0.129	-	3.300	-
J	0.094	-	2.400	-
K	-	0.165	-	4.200
L	0.094	-	2.400	-

Ordering Information

Part Number	Component Package	Quantity	TAPE & REEL
UNS2K40CA	DO-214AB(SMC)	3,000 pcs	13inch

Disclaimer

UNSEMI RESERVES THE RIGHT TO MAKE CHANGE ON OUR PRODUCTS , PRODUCTS SPECIFICATION AND DATA WITHOUT NOTICE TO IMPROVE RELIABILITY, FUNCTION OR DESIGN OR OTHERWISE.

UN SEMICONDUCTOR LIMITED its affiliates, agents, and employees, and all persons acting on its or their behalf (collectively, "UNSEMI") does not give any representations or warranties for any errors, inaccuracies or incompleteness contained in any datasheet or in any other disclosure relating to any product.

In no event shall UNSEMI be liable for any indirect, incidental, punitive, special or consequential damages (including any and all implied warranties, warranties of fitness for particular purpose, non-infringement and merchantability.) whether or not such damages are based on tort (including negligence), warranty, breach of contract or any other legal theory.

Statements regarding the suitability of products for certain types of applications are based on UNSEMI knowledge of typical requirements that are often placed on UNSEMI products in generic applications. Such statements are not binding, statements about the suitability of products for a particular application. It is the customer's responsibility to validate that a particular product with the properties described in the product specification is suitable for use in a particular application. Parameters provided in datasheets or specifications may vary in different applications and performance may vary over time. All operating parameters, including typical parameters, must be validated for each customer application by the customer's technical experts. Product specifications do not expand or otherwise modify UNSEMI's terms and conditions of purchase, including but not limited to the warranty expressed therein.

Unless otherwise agreed in writing, UNSEMI product is not designed, authorized or warranted to be suitable for use in medical life-saving, or life-sustaining application , nor in applications where failure or malfunction of a UNSEMI product can reasonably be expected to result in personal injury, death or severe property or environmental damage. UNSEMI and its suppliers accept no liability for inclusion or use of UNSEMI products in such equipment or applications and therefore such inclusion and/or use is at the customer's own risk.

All referenced brands, product names, service names and trademarks are the property of their respective owners.