

Surface Single Gas Discharge Tube

Description

Gas discharge Tubes (GDT) are classical components for protecting the installations of the telecommunications. It is essential that IT and telecommunications systems -with their high-grade but sensitive electronic circuits - be protected by arresters. They are thus fitted at the input of the power supply system together with varistors and at the connection points to telecommunication lines. They have become equally indispensable for protecting base stations in mobile telephone systems as well as extensive cable television (CATV) networks with their repeaters and distribution systems.

These protective components are also indispensable in other sectors, In AC power transmission systems, they are often used with current-limiting varistors, In customer premises equipment such as DSL modems, WLAN routers, TV sets and cable modems In air-conditioning equipment, the integral black-box concept offers graduated protection by combining arresters with varistors, PTC, diodes and inductor

Agency Approvals

- ◆ Non-Radioactive
- ◆ ROHS compliant
- ◆ Ultra low capacitance
- ◆ Low insertion loss
- ◆ Excellent response to fast rising transients
- ◆ 2-5KA surge capability tested with 8/20µs pulse as defined by IEC 61000-4-5

Applications

- ◆ Communication equipment
- ◆ CATV equipment
- ◆ Test equipment
- ◆ Data lines
- ◆ Power supplies
- ◆ Telecom SLIC protection
- ◆ Broadband equipment
- ◆ ADSL equipment, including ADSL2+
- ◆ XDSL equipment
- ◆ Satellite and CATV equipment
- ◆ Consumer electronics



www.unsemi.com.tw



Schematic Symbol

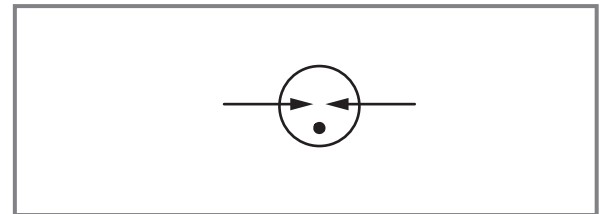

Product Characteristics

Materials	Dull Tin-plated
Product Marking	Without
Glow to Arc Transition Current	< 0.5 Amps
Glow Voltage	~60 Volts
Storage and Operational Temperature	-40 to +90°C
Weight	~0.5g

Device Dimensions (Unit: mm)

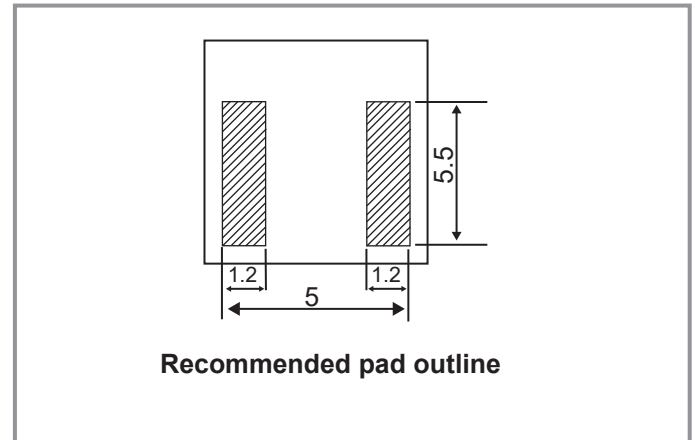
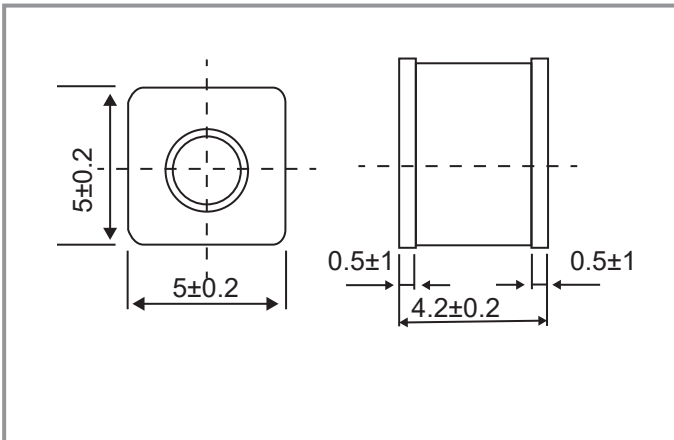

Electrical Characteristics

Part Number	DC Spark-over Voltage	Typical Impulse Spark-over Voltage		Minimum Insulation Resistance	Maximum Capacitance	Arc Voltage	Service Life			
		@100V/μS	@1KV/μS				Nominal Impulse Dis charge Current	Max Impulse Discharge Current	Nominal Alternating Discharge Current	Impulse Life
UN2E5-90LSMD	90±20%	500V	650V	1GΩ (at 50V)	1.0pF	~15V	5KA	10KA	5A	100A
UN2E5-150LSMD	150±20%	500V	650V	1GΩ (at 50V)	1.0pF	~20V	5KA	10KA	5A	100A
UN2E5-200LSMD	200±20%	500V	650V	1GΩ (at 100V)	1.0pF	~20V	5KA	10KA	5A	100A
UN2E5-230LSMD	230±20%	600V	700V	1GΩ (at 100V)	1.0pF	~20V	5KA	10KA	5A	100A
UN2E5-300LSMD	300±20%	700V	800V	1GΩ (at 100V)	1.0pF	~20V	5KA	10KA	5A	100A
UN2E5-350LSMD	350±20%	700V	800V	1GΩ (at 100V)	1.0pF	~20V	5KA	10KA	5A	100A
UN2E5-400LSMD	400±20%	800V	950V	1GΩ (at 100V)	1.0pF	~20V	5KA	10KA	5A	100A
UN2E5-470LSMD	470±20%	900V	1000V	1GΩ (at 100V)	1.0pF	~20V	5KA	10KA	5A	100A
UN2E5-600LSMD	600±20%	1100V	1200V	1GΩ(at 100V)	1.0pF	~20V	5KA	10KA	5A	100A
UN2E5-800LSMD	800±20%	1200V	1400V	1GΩ(at 100V)	1.0pF	~20V	5KA	10KA	5A	100A
UN2E5-1000LSMD	1000±20%	1600V	1800V	1GΩ (at 100V)	0.8pF	~15V	3KA	4KA	3A	100A
UN2E5-1500LSMD	1500±20%	2300V	2500V	1GΩ (at 100V)	0.8pF	~15V	2KA	3KA	2A	100A
UN2E5-2000LSMD	2000±20%	2800V	3000V	1GΩ (at 100V)	0.8pF	~20V	2KA	3KA	2A	100A
UN2E5-2500LSMD	2500±20%	3300V	3600V	1GΩ (at 100V)	0.8pF	~20V	2KA	3KA	2A	100A
UN2E5-2700LSMD	2700±20%	3500V	3800V	1GΩ (at 100V)	0.8pF	~20V	2KA	3KA	2A	100A
UN2E5-3000LSMD	3000±20%	3800V	4000V	1GΩ (at 100V)	0.8pF	~20V	2KA	3KA	2A	100A
UN2E5-3600LSMD	3600±20%	4700V	5000V	1GΩ (at 100V)	0.8pF	~20V	2KA	3KA	2A	100A

Notes:

- 1). Terms in accordance with ITU-T K.12 and GB/T 9043-2008
- 2). At delivery AQL 0.65 level II, DIN ISO 2859

Electrical Rating

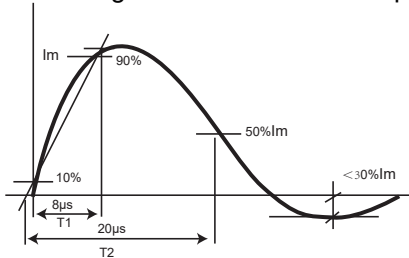
Item	Test Condition Description	Requirement
DC Spark-over Voltage	The voltage is measured with a slowly rate of rise $dv / dt=100V/s$	To meet the specified value
Impulse Spark-over Voltage	The maximum impulse spark-over voltage is measured with a rise time of $dv / dt=100V/\mu s$ or $1KV/\mu s$	
Insulation Resistance	The resistance of gas tube shall be measured each terminal each other terminal, please see above spec.	
Capacitance	The capacitance of gas tube shall be measured each terminal to each other terminal. Test frequency :1MHz	
Nominal Impulse Discharge Current	The maximum current applying a waveform of 8/20 μs that can be applied across the terminals of the gas tube. One hour after the test is completed, re-testing of the DC spark-over voltage does not exceed $\pm 30\%$ of the nominal DC spark-over voltage. Dwell time between pulses is 3 minutes. 	
Nominal Alternating Discharge Current	Rated RMS value of AC current at 50Hz, 1 sec. 10 times. Intervals: 3min. The DC spark-over voltage does not exceed $\pm 30\%$ of the nominal DC spark-over voltage. IR > 10 ⁸ ohms.	

Recommended soldering profile

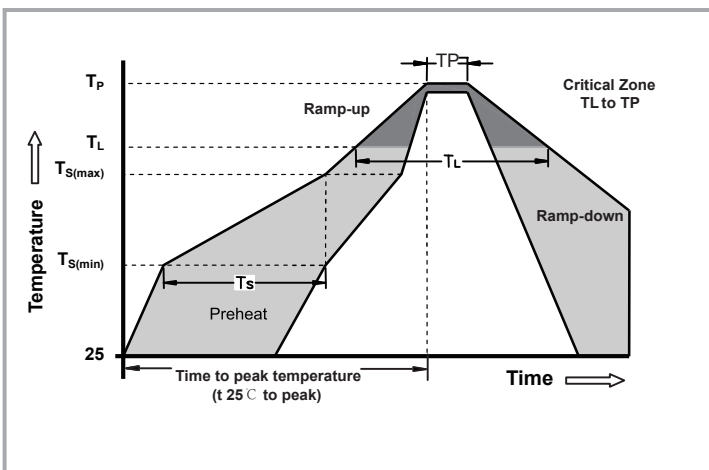

Reflow Condition		pd-Lead-free assembly
Pre Heat	- Temperature Min (Ts(min))	150°C
	- Temperature Max (Ts(max))	200°C
	- Time (min to max) (TS)	60 -180 Seconds
Average ramp up rate (Liquidus Temp TL) to peak		3°C/second max
TS(max) to TL - Ramp-up Rate		5°C/second max
Reflow	- Temperature (TL) (Liquidus)	217°C
	- Time (min to max) (TS)	60 -150 Seconds
Peak Temperature (TP)		260 +0/-5°C
Time within 5°C of actual peak Temperature (TP)		10 - 30 Seconds
Ramp-down Rate		6°C/second max
Time 25°C to peak Temperature (TP)		8 minutes Max
Do not exceed		260°C

Part Numbering

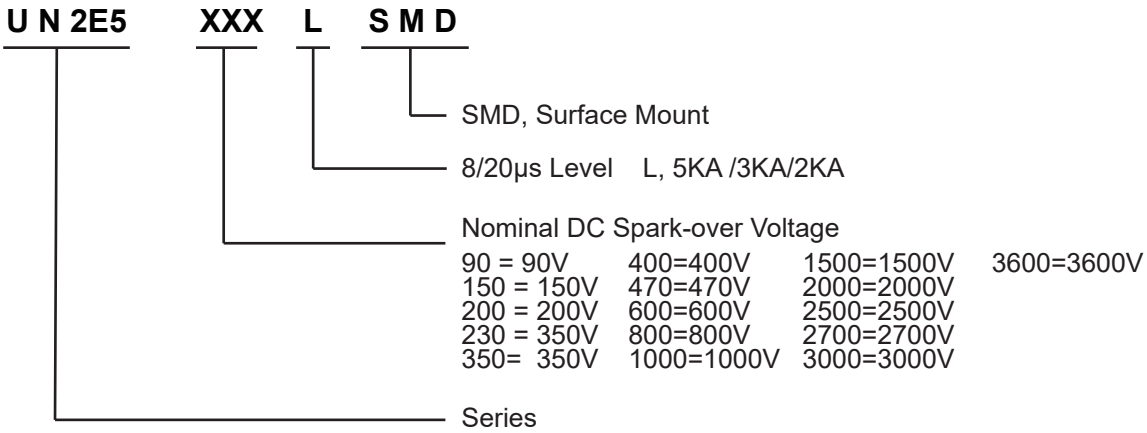

Tape and Reel Dimensions (Unit: mm)

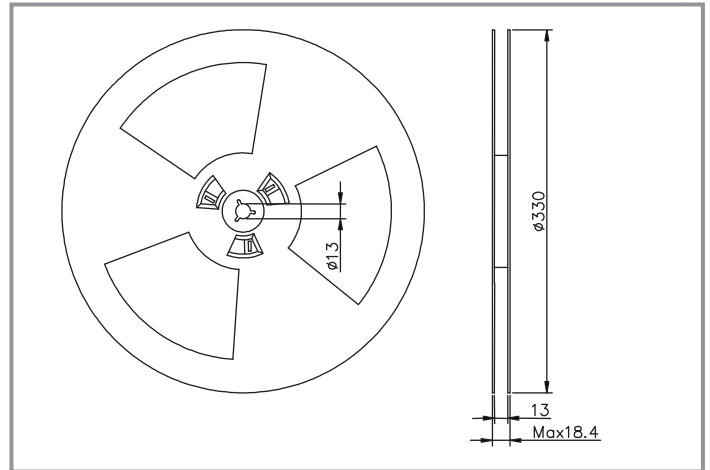
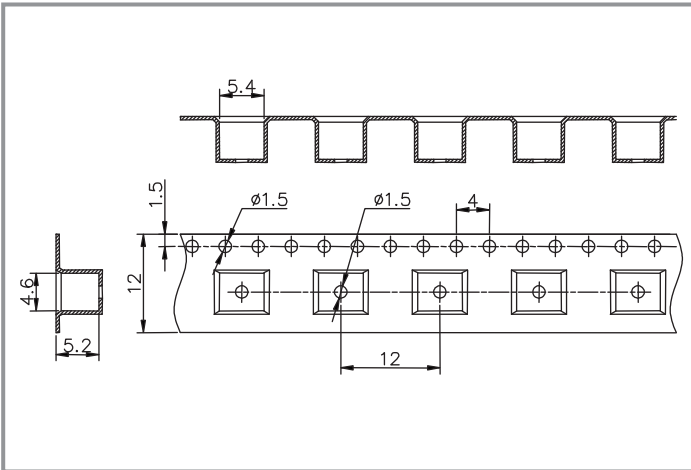

Packaging

Part Number	Description	Quantity
UN2E5-XXXLSMD	Tape & Reel -16mm tape/13"Reel	1000

Cautions and warnings

- ◆ Gas discharge tubes (GDT) must not be operated directly in power supply networks.
- ◆ Gas discharge tubes (GDT) may become hot in case of longer periods of current stress (danger of burning).
- ◆ Gas discharge tubes (GDT) may be used only within their specified values. In the event of overload, the head contacts may fail or the component may be destroyed.
- ◆ Damaged Gas discharge tubes (GDT) must not be re-used.

Disclaimer

UNSEMI RESERVES THE RIGHT TO MAKE CHANGE ON OUR PRODUCTS , PRODUCTS SPECIFICATION AND DATA WITHOUT NOTICE TO IMPROVE RELIABILITY, FUNCTION OR DESIGN OR OTHERWISE.

UN SEMICONDUCTOR LIMITED its affiliates, agents, and employees, and all persons acting on its or their behalf (collectively, "UNSEMI") does not give any representations or warranties for any errors, inaccuracies or incompleteness contained in any datasheet or in any other disclosure relating to any product.

In no event shall UNSEMI be liable for any indirect, incidental, punitive, special or consequential damages (including any and all implied warranties, warranties of fitness for particular purpose, non-infringement and merchantability.) whether or not such damages are based on tort (including negligence), warranty, breach of contract or any other legal theory.

Statements regarding the suitability of products for certain types of applications are based on UNSEMI knowledge of typical requirements that are often placed on UNSEMI products in generic applications. Such statements are not binding, statements about the suitability of products for a particular application. It is the customer's responsibility to validate that a particular product with the properties described in the product specification is suitable for use in a particular application. Parameters provided in datasheets or specifications may vary in different applications and performance may vary over time. All operating parameters, including typical parameters, must be validated for each customer application by the customer's technical experts. Product specifications do not expand or otherwise modify UNSEMI's terms and conditions of purchase, including but not limited to the warranty expressed therein.

Unless otherwise agreed in writing, UNSEMI product is not designed, authorized or warranted to be suitable for use in medical life-saving, or life-sustaining application , nor in applications where failure or malfunction of a UNSEMI product can reasonably be expected to result in personal injury, death or severe property or environmental damage. UNSEMI and its suppliers accept no liability for inclusion or use of UNSEMI products in such equipment or applications and therefore such inclusion and/or use is at the customer's own risk.

All referenced brands, product names, service names and trademarks are the property of their respective owners.