

Single Gas Discharge Tube

Description

Gas discharge Tubes (GDT) are classical components for protecting the installations of the telecommunications. It is essential that IT and telecommunications systems -with their high-grade but sensitive electronic circuits - be protected by arresters. They are thus fitted at the input of the power supply system together with varistors and at the connection points to telecommunication lines. They have become equally indispensable for protecting base stations in mobile telephone systems as well as extensive cable television (CATV) networks with their repeaters and distribution systems.

These protective components are also indispensable in other sectors, In AC power transmission systems, they are often used with current-limiting varistors, In customer premises equipment such as DSL modems, WLAN routers, TV sets and cable modems In air-conditioning equipment, the integral black-box concept offers graduated protection by combining arresters with varistors, PTC, diodes and inductor

Features

- ◆ Non-Radioactive
- ◆ ROHS compliant
- ◆ Ultra low capacitance
- ◆ Low insertion loss
- ◆ Excellent response to fast rising transients
- ◆ 10~20KA surge capability tested with 8/20 μ s pulse as defined by IEC 61000-4-5

Applications

- ◆ Communication equipment
- ◆ CATV equipment
- ◆ Test equipment
- ◆ Data lines
- ◆ Power supplies
- ◆ Instrumentation circuits
- ◆ Medical electronics
- ◆ ADSL equipment
- ◆ Telecom SLIC protection



www.unsemi.com.tw

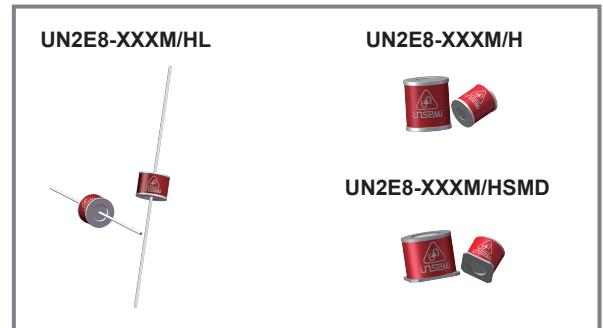

Schematic Symbol

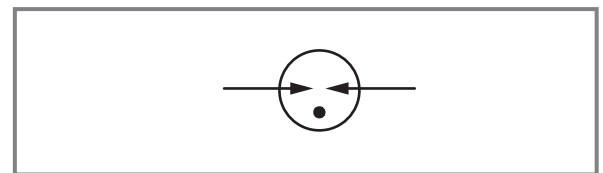

Agency Approvals

AGENCY	AGENCY FIL ENUMBER
	E466847

Product Characteristics

Materials	Leaded Device: Nickel-plated with Tinplated wires Surface Mount: Dull Tin-plated	
Product Marking	XXX -Nominal voltage M - 10KA H - 20KA	
Glow to Arc Transition Current	< 0.5 Amps	
Glow Voltage	~60 Volts	
Storage and Operational Temperature	-40 to +90°C	
Weight	UN2E8-XXXML	~1.5g
	UN2E8-XXXHL	~1.6g
	UN2E8-XXXM/H	~1.4g
	UN2E8-XXXM/HSMD	~1.5g

Dimensions (Unit: mm)

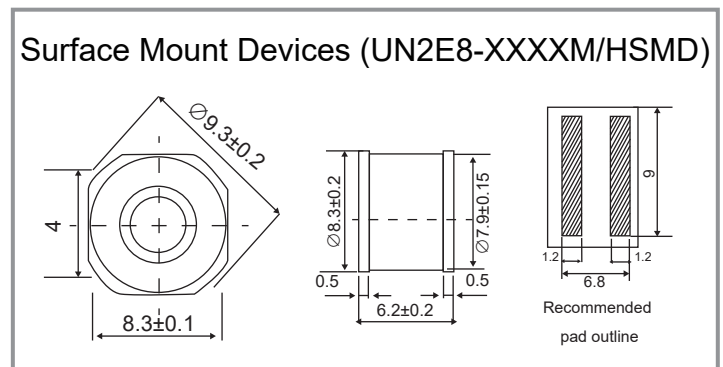
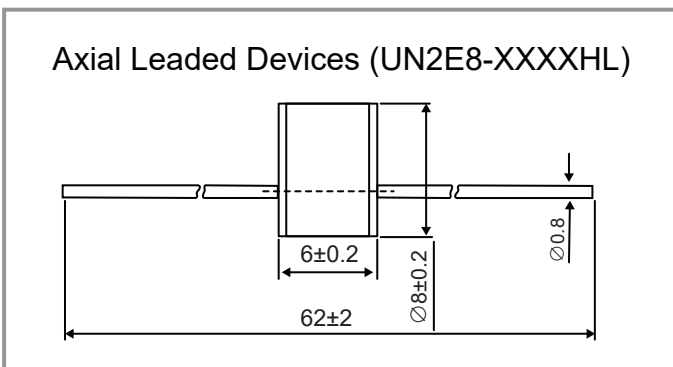
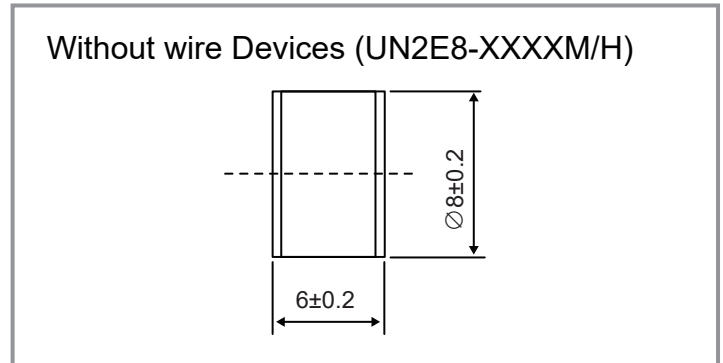
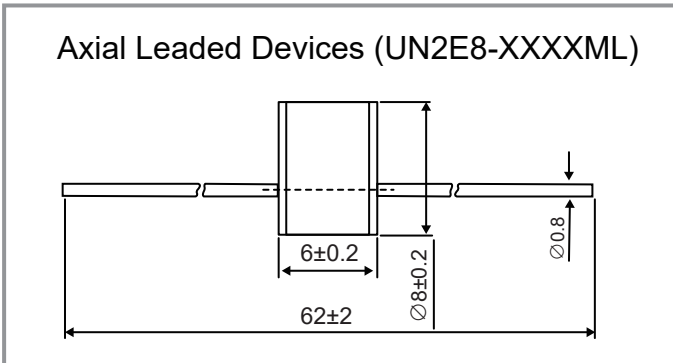

Electrical Characteristics

Part Number	Marking	DC Spark-over Voltage	Typical Impulse Spark-over Voltage		Minimum Insulation Resistance	Maximum Capacitance	Arc Voltage	Service Life			
			@100V/μS	@1KV/μS				Nominal Impulse Discharge Current	Max Impulse Discharge Current	Nominal Alternating Discharge Current	Impulse Life
UN2E8-75M UN2E8-75ML UN2E8-75MSMD	75M	75V±20%	500V	600V	1GΩ (at 100V)	1.5pF	~15V	10KA	20KA	10A	100A
UN2E8-90M UN2E8-90ML UN2E8-90MSMD	90M	90V±20%	500V	600V	1GΩ (at 100V)	1.5pF	~15V	10KA	20KA	10A	100A
UN2E8-150M UN2E8-150ML UN2E8-150MSMD	150M	150V±20%	500V	600V	1GΩ (at 100V)	1.5pF	~20V	10KA	20KA	10A	100A
UN2E8-230M UN2E8-230ML UN2E8-230MSMD	230M	230V±20%	600V	700V	1GΩ (at 100V)	1.5pF	~20V	10KA	20KA	10A	100A
UN2E8-250M UN2E8-250ML UN2E8-250MSMD	250M	250V±20%	700V	800V	1GΩ (at 100V)	1.5pF	~20V	10KA	20KA	10A	100A
UN2E8-300M UN2E8-300ML UN2E8-300MSMD	300M	300V±20%	800V	900V	1GΩ (at 100V)	1.5pF	~20V	10KA	20KA	10A	100A
UN2E8-350M UN2E8-350ML UN2E8-350MSMD	350M	350V±20%	800V	900V	1GΩ (at 100V)	1.5pF	~20V	10KA	20KA	10A	100A

Electrical Characteristics (Continue)

Part Number	Marking	DC Spark-over Voltage	Typical Insulation Spark-over Voltage		Minimum Insulation Resistance	Maximum Capacitance	Arc Voltage	Service Life			
								Nominal Impulse Discharge Current	Max Impulse Discharge Current	Nominal Alternating Discharge Current	Impulse Life
								@100V/S	@100V/μS	@1KV/μS	@1MHz
UN2E8-420M UN2E8-420ML UN2E8-420MSMD	420M	420V±20%	900V	1000V	1GΩ (at 100V)	1.5pF	~20V	10KA	20KA	10A	100A
UN2E8-470M UN2E8-470ML UN2E8-470MSMD	470M	470V±20%	900V	1000V	1GΩ (at 100V)	1.5pF	~20V	10KA	20KA	10A	100A
UN2E8-600M UN2E8-600ML UN2E8-600MSMD	600M	600V±20%	1100V	1200V	1GΩ (at 50V)	1.5pF	~20V	10KA	20KA	10A	100A
UN2E8-800M UN2E8-800ML UN2E8-800MSMD	800M	800V±20%	1200V	1400V	1GΩ (at 100V)	1.5pF	~20V	10KA	20KA	10A	100A

UN2E8-75H UN2E8-75HL UN2E8-75HSMD	75H	75V±20%	500V	600V	1GΩ (at 25V)	1.5pF	~15V	20KA	25KA	20A	200A
UN2E8-90H UN2E8-90HL UN2E8-90HSMD	90H	90V±20%	500V	600V	1GΩ (at 50V)	1.5pF	~15V	20KA	25KA	20A	200A
UN2E8-150H UN2E8-150HL UN2E8-150HSMD	150H	150V±20%	500V	600V	1GΩ (at 50V)	1.5pF	~20V	20KA	25KA	20A	200A
UN2E8-230H UN2E8-230HL UN2E8-230HSMD	230H	230V±20%	600V	700V	1GΩ (at 100V)	1.5pF	~20V	20KA	25KA	20A	200A
UN2E8-250H UN2E8-250HL UN2E8-250HSMD	250H	250V±20%	700V	800V	1GΩ (at 100V)	1.5pF	~20V	20KA	25KA	20A	200A
UN2E8-300H UN2E8-300HL UN2E8-300HSMD	300H	300V±20%	800V	900V	1GΩ (at 100V)	1.5pF	~20V	20KA	25KA	20A	200A
UN2E8-350H UN2E8-350HL UN2E8-350HSMD	350H	350V±20%	800V	900V	1GΩ (at 100V)	1.5pF	~20V	20KA	25KA	20A	200A
UN2E8-420H UN2E8-420HL UN2E8-420HSMD	420H	420V±20%	900V	1000V	1GΩ (at 100V)	1.5pF	~20V	20KA	25KA	20A	200A
UN2E8-470H UN2E8-470HL UN2E8-470HSMD	470H	470V±20%	900V	1000V	1GΩ (at 100V)	1.5pF	~20V	20KA	25KA	20A	200A
UN2E8-600H UN2E8-600HL UN2E8-600HSMD	600H	600V±20%	1100V	1200V	1GΩ (at 100V)	1.5pF	~20V	20KA	25KA	20A	200A
UN2E8-800H UN2E8-800HL UN2E8-800HSMD	800H	800V±20%	1200V	1400V	1GΩ (at 100V)	1.5pF	~20V	20KA	25KA	20A	200A

Notes:

- 1). Terms in accordance with ITU-T K.12 and GB/T 9043-2008
- 2). At delivery AQL 0.65 level II, DIN ISO 2859

Electrical Rating

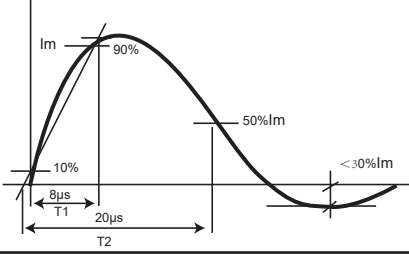
Item	Test Condition / Description	Requirement
DC Spark-over Voltage	The voltage is measured with a slowly rate of rise $dv / dt=100V/s$	To meet the specified value
Impulse Spark-over Voltage	The maximum impulse spark-over voltage is measured with a rise time of $dv / dt=100V/\mu s$ or $1KV/\mu s$	
Insulation Resistance	The resistance of gas tube shall be measured each terminal each other terminal, please see above spec.	
Capacitance	The capacitance of gas tube shall be measured each terminal to each other terminal. Test frequency :1MHz	
Nominal Impulse Discharge Current	The maximum current applying a waveform of 8/20 μs that can be applied across the terminals of the gas tube. One hour after the test is completed, re-testing of the DC spark-over voltage does not exceed $\pm 30\%$ of the nominal DC spark-over voltage. Dwell time between pulses is 3 minutes. 	
Nominal Alternating Discharge Current	Rated RMS value of AC current at 50Hz, 1 sec. 10 times. Intervals: 3min. The DC spark-over voltage does not exceed $\pm 30\%$ of the nominal DC spark-over voltage. IR > 10^8 ohms.	

Recommended soldering profile

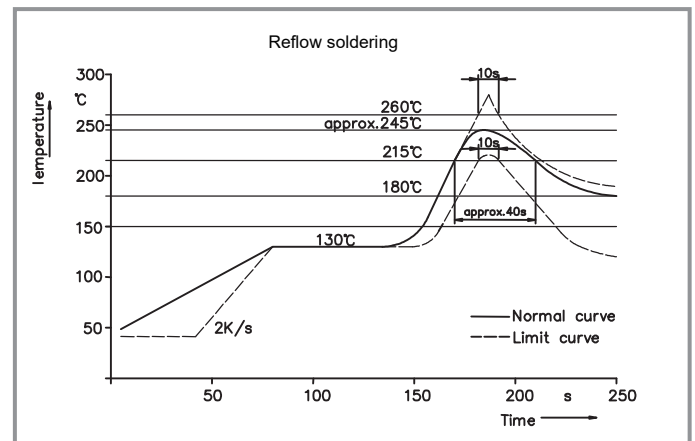
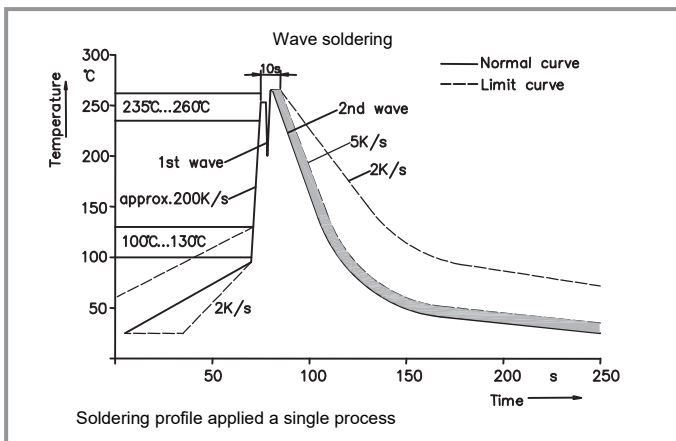

Soldering Parameters - Hand Soldering

Solder Iron Temperature: 350°C +/-5°C
Heating Time: 5 seconds max.

Part Numbering

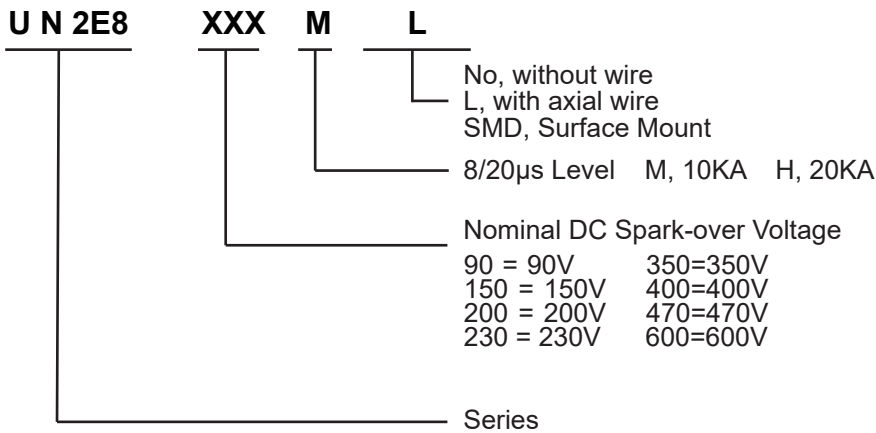

Packaging Information (Unit: mm)

Part Number	Description	Quantity
UN2E8-XXXM / UN2E8XXXH	Tape & Reel -16mm tape/13"Reel	500
UN2E8-XXXML / UN2E8XXXHL	T800PCS per Tape & Reel	800
UN2E8-XXXMSMD / UN2E8XXXHSMD	100PCS per Tray, 10 Trays / Inner Carton	1000
	Tape & Reel -16mm tape/13"Reel	500

Tray used in UN2E8-XXXML/ UN2E8-XXXHL

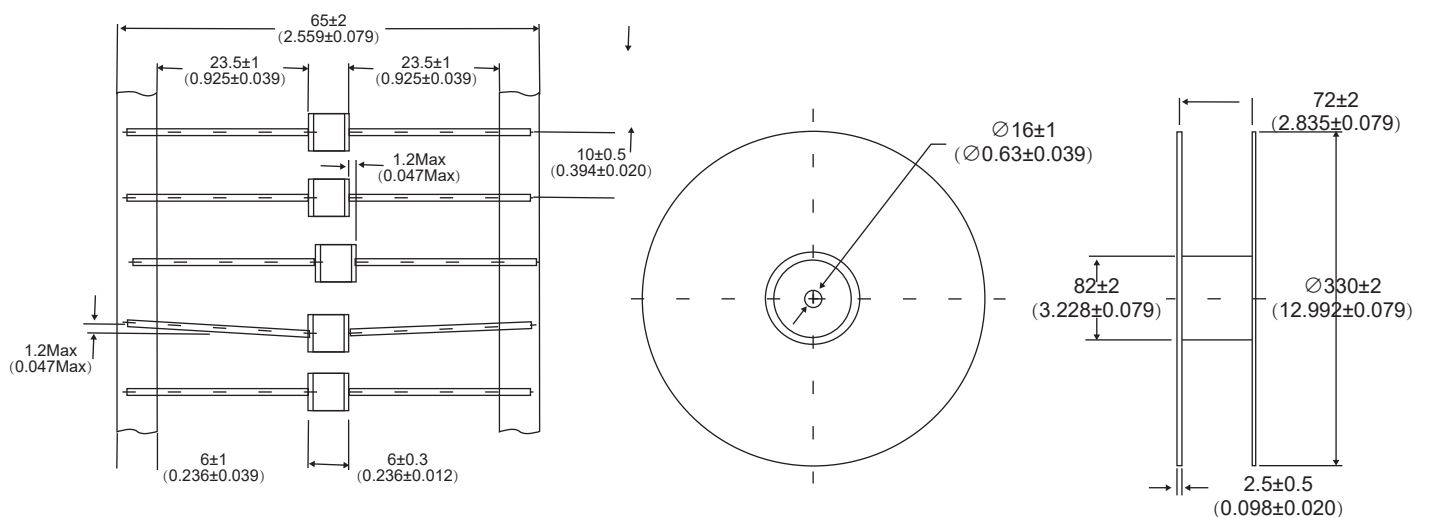

Tape and Reel Dimensions (Unit: mm)

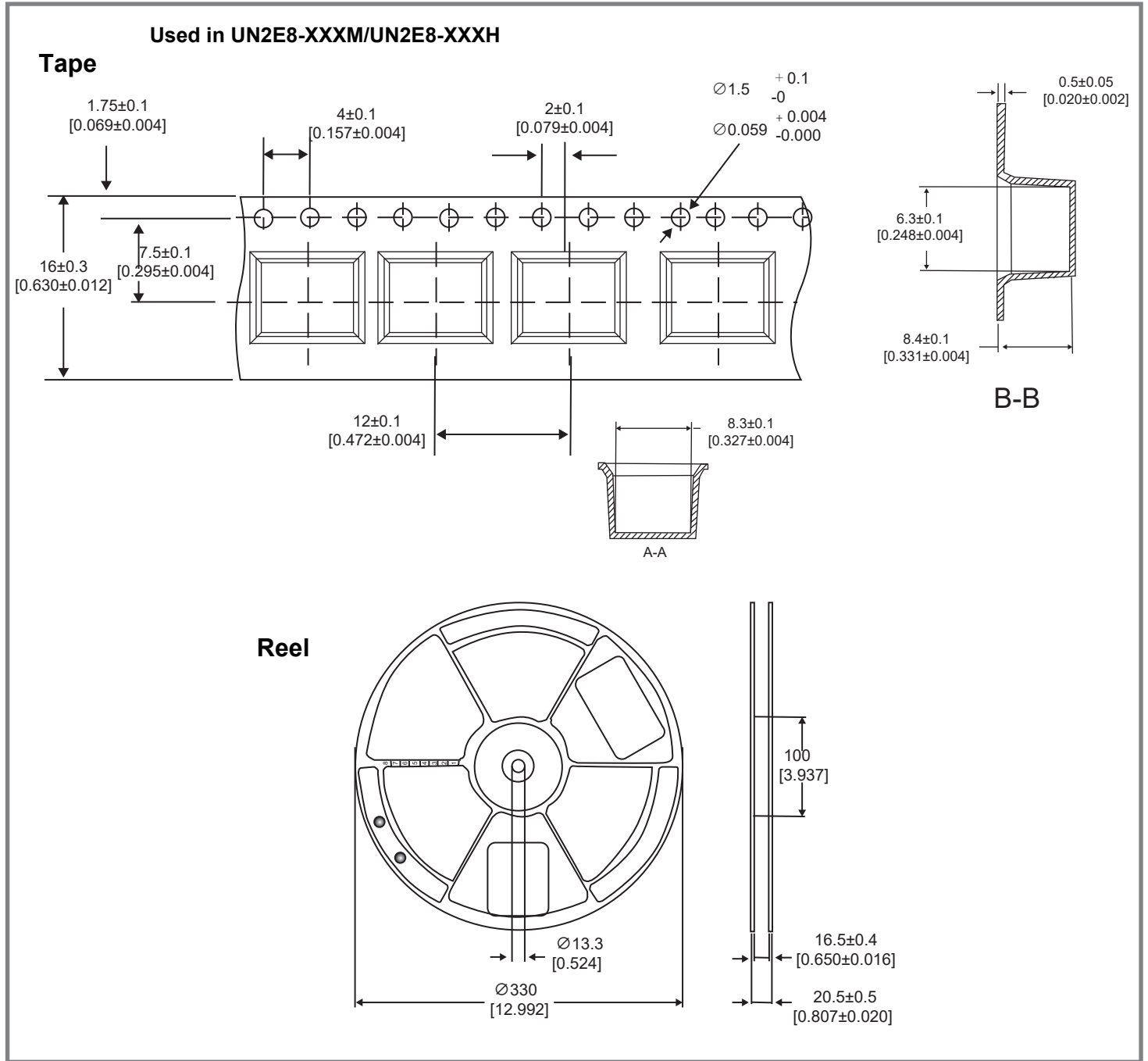

Tape and Reel Dimensions (Unit: mm)

Used in UN2E8-XXXMSMD /UN2E8-XXXHSMD

Tape

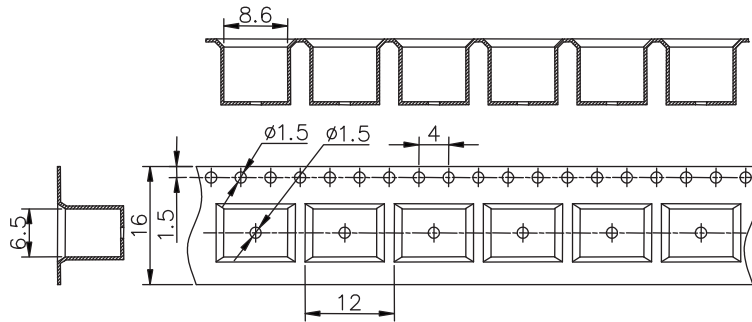

Reel

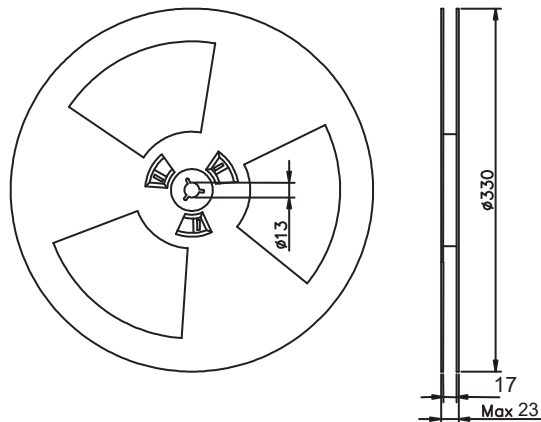

Cautions and warnings

- ◆ Gas discharge tubes (GDT) must not be operated directly in power supply networks.
- ◆ Gas discharge tubes (GDT) may become hot in case of longer periods of current stress (danger of burning).
- ◆ Gas discharge tubes (GDT) may be used only within their specified values. In the event of overload, the head contacts may fail or the component may be destroyed.
- ◆ Damaged Gas discharge tubes (GDT) must not be re-used.

Disclaimer

UNSEMI RESERVES THE RIGHT TO MAKE CHANGE ON OUR PRODUCTS , PRODUCTS SPECIFICATION AND DATA WITHOUT NOTICE TO IMPROVE RELIABILITY, FUNCTION OR DESIGN OR OTHERWISE.

UN SEMICONDUCTOR LIMITED its affiliates, agents, and employees, and all persons acting on its or their behalf (collectively, "UNSEMI") does not give any representations or warranties for any errors, inaccuracies or incompleteness contained in any datasheet or in any other disclosure relating to any product.

In no event shall UNSEMI be liable for any indirect, incidental, punitive, special or consequential damages (including any and all implied warranties, warranties of fitness for particular purpose, non-infringement and merchantability.) whether or not such damages are based on tort (including negligence), warranty, breach of contract or any other legal theory.

Statements regarding the suitability of products for certain types of applications are based on UNSEMI knowledge of typical requirements that are often placed on UNSEMI products in generic applications. Such statements are not binding, statements about the suitability of products for a particular application. It is the customer's responsibility to validate that a particular product with the properties described in the product specification is suitable for use in a particular application. Parameters provided in datasheets or specifications may vary in different applications and performance may vary over time. All operating parameters, including typical parameters, must be validated for each customer application by the customer's technical experts. Product specifications do not expand or otherwise modify UNSEMI's terms and conditions of purchase, including but not limited to the warranty expressed therein.

Unless otherwise agreed in writing, UNSEMI product is not designed, authorized or warranted to be suitable for use in medical life-saving, or life-sustaining application , nor in applications where failure or malfunction of a UNSEMI product can reasonably be expected to result in personal injury, death or severe property or environmental damage. UNSEMI and its suppliers accept no liability for inclusion or use of UNSEMI products in such equipment or applications and therefore such inclusion and/or use is at the customer's own risk.

All referenced brands, product names, service names and trademarks are the property of their respective owners.