

## Double line Gas Discharge Tube

### Description

Gas discharge Tubes (GDT) are classical components for protecting the installations of the telecommunications. It is essential that IT and telecommunications systems -with their high-grade but sensitive electronic circuits - be protected by arresters. They are thus fitted at the input of the power supply system together with varistors and at the connection points to telecommunication lines. They have become equally indispensable for protecting base stations in mobile telephone systems as well as extensive cable television (CATV) networks with their repeaters and distribution systems.

These protective components are also indispensable in other sectors, In AC power transmission systems, they are often used with current-limiting varistors, In customer premises equipment such as DSL modems, WLAN routers, TV sets and cable modems In air-conditioning equipment, the integral black-box concept offers graduated protection by combining arresters with varistors, PTC, diodes and inductor

### Features

- ◆ Non-Radioactive
- ◆ ROHS compliant
- ◆ Ultra low capacitance
- ◆ Low insertion loss
- ◆ Excellent response to fast rising transients
- ◆ 5KA surge capability tested with 8/20µs pulse as defined by IEC 61000-4-5

### Applications

- ◆ Communication equipment
- ◆ CATV equipment
- ◆ Test equipment
- ◆ Data lines
- ◆ Power supplies
- ◆ Telecom SLIC protection
- ◆ Broadband equipment
- ◆ ADSL equipment, including ADSL2+
- ◆ XDSL equipment
- ◆ Satellite and CATV equipment
- ◆ Consumer electronics



www.unsemi.com.tw

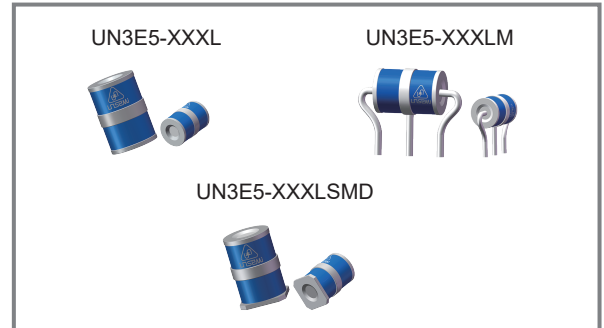

### Schematic Symbol

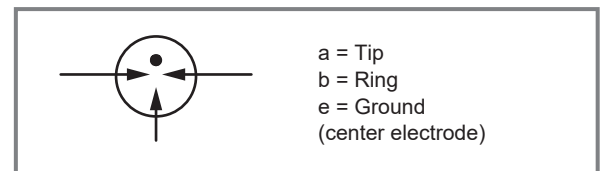

### Agency Approvals

AGENCY	AGENCY FIL ENUMBER
	E466847

### Product Characteristics

Materials	Leaded Device: Nickel-plated with Tinned wires Surface Mount: Dull Tin-plated	
Product Marking	XXXL XXX -Nominal voltage L -5KA	
Glow to Arc Transition Current	< 0.5 Amps	
Glow Voltage	~60 Volts	
Storage and Operational Temperature	-40 to +90°C	
Weight	UN3E5-XXXLM	~0.8g
	UN3E5-XXXL	~0.7g
	UN3E5-XXXLSMD	~0.7g

### Dimensions (Unit: mm)

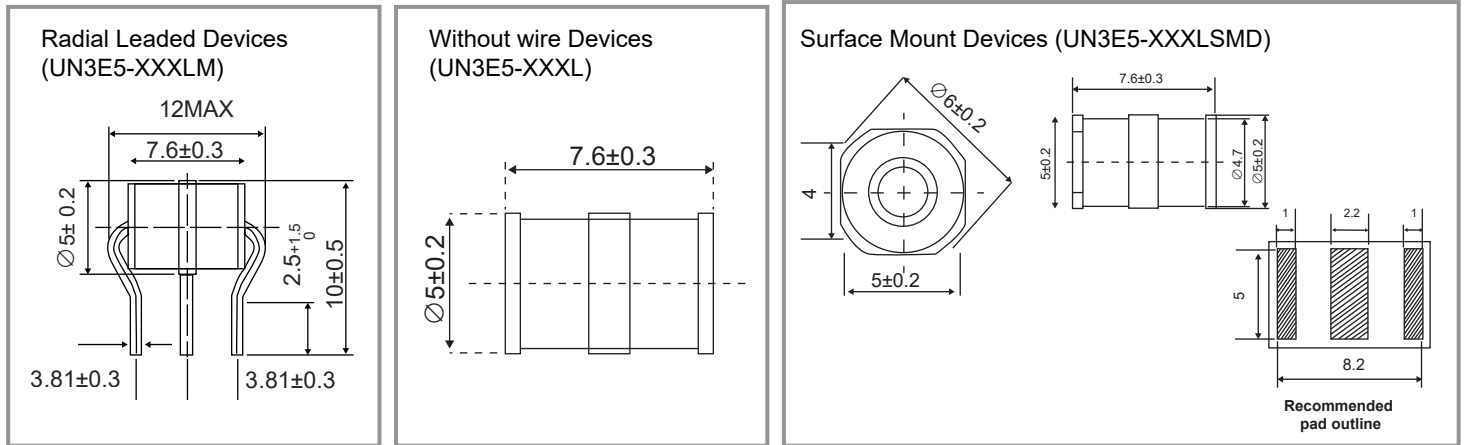

### Electrical Characteristics

Part Number	Marking	DC Spark-over Voltage	Typical Impulse Spark-over Voltage		Minimum Insulation Resistance	Maximum Capacitance	Arc Voltage	Service Life				
			@100V/μS	@100V/μS				@1KV/μS	Nominal Impulse Discharge Current	Max Impulse Discharge Current	Nominal Alternating Discharge Current	Impulse Life
UN3E5-75LM UN3E5-75L UN3E5-75LSMD	75L	75V±20%	500V	600V	1GΩ (at 25V)	1.5pF	~15V	5KA	10KA	5A	200A	
UN3E5-90LM UN3E5-90L UN3E5-90LSMD	90L	90V±20%	500V	600V	1GΩ (at 50V)	1.5pF	~15V	5KA	10KA	5A	200A	
UN3E5-150LM UN3E5-150L UN3E5-150LSMD	150L	150V±20%	500V	600V	1GΩ (at 50V)	1.5pF	~20V	5KA	10KA	5A	200A	
UN3E5-230LM UN3E5-230L UN3E5-230LSMD	230L	230V±20%	600V	700V	1GΩ (at 100V)	1.5pF	~20V	5KA	10KA	5A	200A	
UN3E5-250LM UN3E5-250L UN3E5-250LSMD	250L	250V±20%	600V	700V	1GΩ (at 100V)	1.5pF	~20V	5KA	10KA	5A	200A	
UN3E5-300LM UN3E5-300L UN3E5-300LSMD	300L	300V±20%	800V	900V	1GΩ (at 100V)	1.5pF	~20V	5KA	10KA	5A	200A	
UN3E5-350LM UN3E5-350L UN3E5-350LSMD	350L	350V±20%	800V	900V	1GΩ (at 100V)	1.5pF	~20V	5KA	10KA	5A	200A	
UN3E5-420LM UN3E5-420L UN3E5-420LSMD	420L	420V±20%	900V	1000V	1GΩ (at 100V)	1.5pF	~20V	5KA	10KA	5A	200A	
UN3E5-470LM UN3E5-470L UN3E5-470LSMD	470L	470V±20%	900V	1000V	1GΩ (at 100V)	1.5pF	~20V	5KA	10KA	5A	200A	
UN3E5-600LM UN3E5-600L UN3E5-600LSMD	600L	600V±20%	1100V	1200V	1GΩ (at 100V)	1.5pF	~20V	5KA	10KA	5A	200A	

Notes:

- 1). Terms in accordance with ITU-T K.12 and GB/T 9043-2008
- 2). At delivery AQL 0.65 level II, DIN ISO 2859
- 3). Tip or ring electrode to center electrode
- 4). Total current through center electrode, half value through tip respectively ring electrode

## Electrical Rating

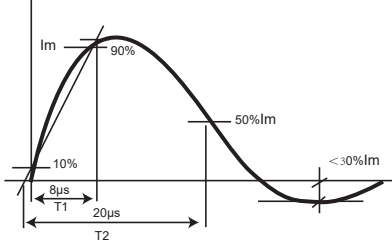
Item	Test Condition / Description	Requirement
DC Spark-over Voltage	The voltage is measured with a slowly rate of rise $dv / dt=100V/s$	To meet the specified value
Impulse Spark-over Voltage	The maximum impulse spark-over voltage is measured with a rise time of $dv / dt=100V/\mu s$ or $1KV/\mu s$	
Insulation Resistance	The resistance of gas tube shall be measured each terminal each other terminal, please see above spec.	
Capacitance	The capacitance of gas tube shall be measured each terminal to each other terminal. Test frequency :1MHz	
Nominal Impulse Discharge Current	The maximum current applying a waveform of $8/20\mu s$ that can be applied across the terminals of the gas tube. One hour after the test is completed, re-testing of the DC spark-over voltage does not exceed $\pm 30\%$ of the nominal DC spark-over voltage. Dwell time between pulses is 3 minutes. 	
Nominal Alternating Discharge Current	Rated RMS value of AC current at 50Hz, 1 sec. 10 times. Intervals: 3min. The DC spark-over voltage does not exceed $\pm 30\%$ of the nominal DC spark-over voltage. $IR > 10^8$ ohms.	

## Recommended soldering profile

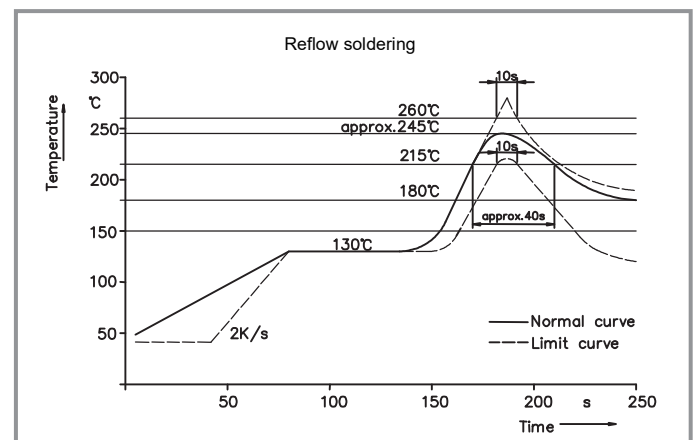
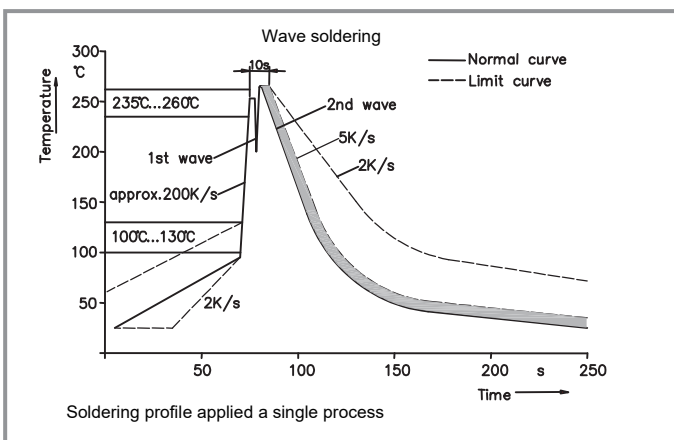

## Soldering Parameters - Hand Soldering

Solder Iron Temperature: 350°C  $\pm 5^\circ C$   
Heating Time: 5 seconds max.

### Part Numbering

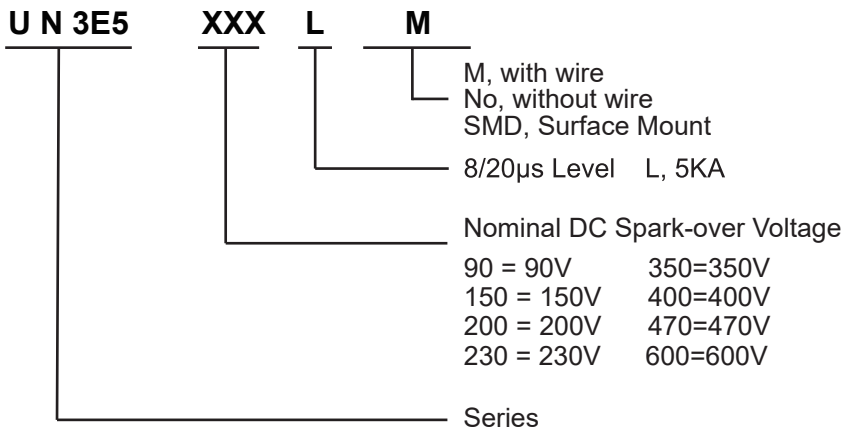

### Packaging

Part Number	Description	Quantity
UN3E5-XXXLM	100PCS per Tray, 10 Trays / Inner Carton	500
UN3E5-XXXL	1000PCS per Tray, 10 Trays / Inner Carton	1000
UN3E5-XXXLSMD	1000PCS per Tray, 10 Trays / Inner Carton	1000
	16mmTape & 13" Reel	1000

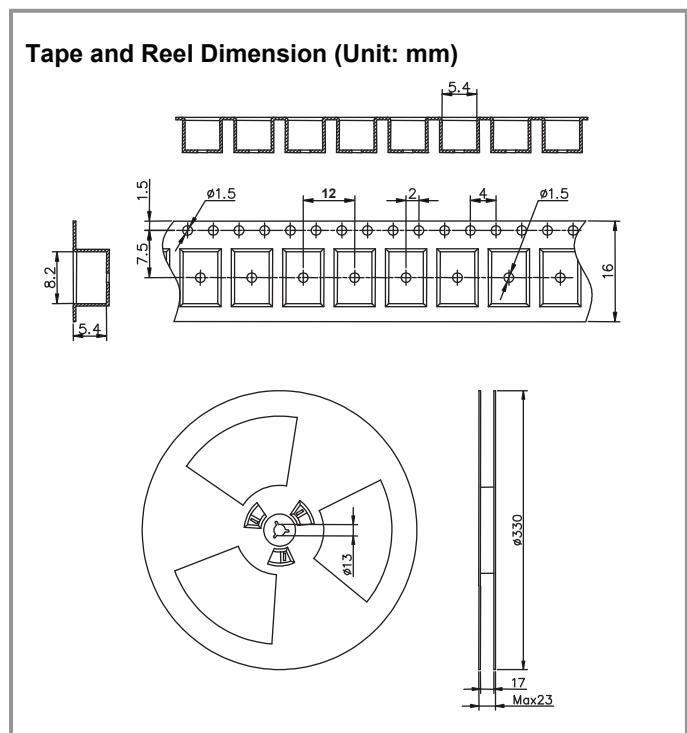
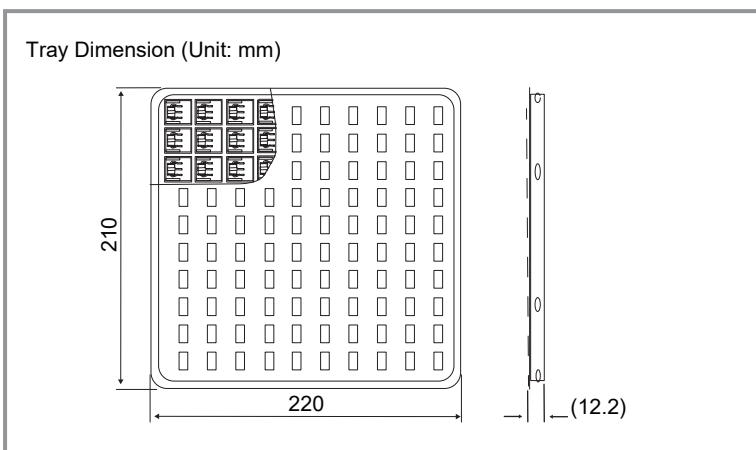

### Cautions and warnings

- ◆ Gas discharge tubes (GDT) must not be operated directly in power supply networks.
- ◆ Gas discharge tubes (GDT) may become hot in case of longer periods of current stress (danger of burning).
- ◆ Gas discharge tubes (GDT) may be used only within their specified values. In the event of overload, the head contacts may fail or the component may be destroyed.
- ◆ Damaged Gas discharge tubes (GDT) must not be re-used.

## Disclaimer

UNSEMI RESERVES THE RIGHT TO MAKE CHANGE ON OUR PRODUCTS , PRODUCTS SPECIFICATION AND DATA WITHOUT NOTICE TO IMPROVE RELIABILITY, FUNCTION OR DESIGN OR OTHERWISE.

UN SEMICONDUCTOR LIMITED its affiliates, agents, and employees, and all persons acting on its or their behalf (collectively, "UNSEMI") does not give any representations or warranties for any errors, inaccuracies or incompleteness contained in any datasheet or in any other disclosure relating to any product.

In no event shall UNSEMI be liable for any indirect, incidental, punitive, special or consequential damages (including any and all implied warranties, warranties of fitness for particular purpose, non-infringement and merchantability.) whether or not such damages are based on tort (including negligence), warranty, breach of contract or any other legal theory.

Statements regarding the suitability of products for certain types of applications are based on UNSEMI knowledge of typical requirements that are often placed on UNSEMI products in generic applications. Such statements are not binding, statements about the suitability of products for a particular application. It is the customer's responsibility to validate that a particular product with the properties described in the product specification is suitable for use in a particular application. Parameters provided in datasheets or specifications may vary in different applications and performance may vary over time. All operating parameters, including typical parameters, must be validated for each customer application by the customer's technical experts. Product specifications do not expand or otherwise modify UNSEMI's terms and conditions of purchase, including but not limited to the warranty expressed therein.

Unless otherwise agreed in writing, UNSEMI product is not designed, authorized or warranted to be suitable for use in medical life-saving, or life-sustaining application , nor in applications where failure or malfunction of a UNSEMI product can reasonably be expected to result in personal injury, death or severe property or environmental damage. UNSEMI and its suppliers accept no liability for inclusion or use of UNSEMI products in such equipment or applications and therefore such inclusion and/or use is at the customer's own risk.

All referenced brands, product names, service names and trademarks are the property of their respective owners.